

**SRI GURU NANAK PUBLIC SCHOOL  
SUMMER HOLIDAY HOMEWORK (2023-24)  
CLASS VIII**

**SUBJECT- ENGLISH**

1. Read the novel *The invisible man* by H G Wells. Find 50 difficult words with their meanings and a book review in an A4 size sheet. Make a book cover for the novel.
2. Write any fifteen idioms on an A4 size sheet and make sentences using them.
3. You recently visited Lakshadweep, Andaman and Nicobar Islands in your holidays. Write a diary entry about all the places you visited during your trip in 200 words. Paste pictures along with it on an A3 size sheet.  
Roll no (1-25) on Lakshadweep.  
Roll no (26-26) Andaman and Nicobar Islands.
4. Solve the following worksheets in A4 size ruled sheet in a file:

**WORKSHEET 1:**

Make sentences in the present perfect tense using the verb form given in the brackets.

1. The boys ..... in their answer sheets. (hand)
2. The people ..... the city. (desert)
3. I ..... confirmation of the news. (receive)
4. We ..... in this city for twenty years. (live)
5. She ..... the first prize for her stupendous performance. (win)
6. The boys ..... their meals. (eat)
7. The lions ..... the bison. (kill)
8. The police ..... the smugglers. (arrest)
9. The child ..... his homework. (do)
10. I ..... the table. (lay)
11. They ..... the books. (print)
12. The spider ..... its web. (weave)
13. The birds ..... home to roost. (come)
14. The trees ..... blooming. (start)

## WORKSHEET 2

Fill in the blanks using the present continuous tense form of the verb.

1. She ..... for her exams. (prepare)
2. I ..... in the afternoon. (leave)
3. The birds ..... (chirp)
4. The students ..... to school. (go)
5. Grandma ..... in the afternoon. (arrive)
6. They ..... to lose hope. (start)
7. He ..... for us. (wait)
8. Somebody ..... at the gate. (stand)
9. Don't make a noise. The baby ..... (sleep)
10. She ..... for a job. (look)
11. Rani ..... with her parents at the moment. (stay)
12. Stella and Martin ..... married in July. (get)

## WORKSHEET 3

Fill in the blanks with a simple past or present perfect tense form.

1. I ..... your father yesterday. (saw / have seen)
2. He ..... in 2014. (graduated / has graduated)
3. I ..... school at fourteen. (left / have left)
4. She ..... a nice apartment in the city. (bought / has bought)
5. I ..... a lion. (never saw / have never seen)
6. .... the television adaptation of Romeo and Juliet yesterday? (Did you watch / Have you watched)
7. .... that movie? (Did you see / Have you seen)
8. Yesterday, I ..... my children to the park. (took / have taken)
9. She ..... a new job. (found / has found)
10. I ..... the parcel in the morning. (received / have received)

## WORKSHEET 4

### Expanding Your Vocabulary

Read the paragraph below. Replace the underlined words with more precise words. Choose from the words below to replace the underlined words with more colorful, precise language.

I have always been (1) receptive to people in trouble; they know that it will be impossible for me to be (2) uncaring to their story. Every friend, and even (3) stranger, that I have ever had has sought me out during the (4) tough times in their lives, and I (5) always (6) help them. I (7) put this aspect of my character to being raised by a mother with (8) famous generosity and a father who believed in giving people a hand-up, rather than a handout, and they passed this stance on to me. So whenever my friends are (9) bothered by one of life's (10) troubles, they know they can count on me not to do things for them, but to help them figure out how make things better for themselves.

indifferent	1.	_____
accommodate	2.	_____
susceptible	3.	_____
turbulent	4.	_____
acquaintance	5.	_____
invariably	6.	_____
attribute	7.	_____
legendary	8.	_____
beleaguered	9.	_____
onslaughts	10.	_____



विषय- हिंदी

कक्षा- अष्टम

ग्रीष्मवकाश गृह कार्य(2023-24)

(क) प्रति दिन एक सलु खे लि खो। लखे नी स्पष्ट एवं संदुर हो।

(ख) समाचार पत्र पढ़ो तथा कठिन शब्दों का शब्दकोश बनाइए।

(ग) कक्षा मेंकरवाया गया कार्य परख करो तथा याद करो।

(घ) कि सी भी विषय पर एक चार्ट बनाइए।

(ङ) रोल नंबर 1 से 25 लक्ष्यदीप पर एक प्रोजेक्ट बनाएं गे जि सका विषय लक्ष्यदीप के पर्यटन स्थल।

(च) रोल नंबर 26 से 45 अं डमान नि कोबार पर एक प्रोजेक्ट तयै ार करेंगे जि सका विषय है वहां के खाद्य पदार्थ।

## HOLIDAYS HOME WORK (2022-23)

CLASS-VIII

SUB- PUNJABI

- 10 ਸੁਲੇਖ ਲਿਖੋ।
- ਆਪਣਾ ਮਨਪਸੰਦ ਖਾਣਾ ਬਣਾਉਣ ਦੀ ਸਮੱਗਰੀ ਅਤੇ ਵਿਧੀ ਲਿਖੋ (recipe and ingredient)
- ਜਮਾਤ ਵਿੱਚ ਕਰਵਾਏ ਕੰਮ ਦੀ ਦੁਹਰਾਈ ਕਰੋ।
- ਲਕਸ਼ਦੀਪ , ਅੰਡੇਮਾਨ ਅਤੇ ਨਿਕੋਬਾਰ।  
ਰੋਲ ਨੰਬਰ (1 ਤੋਂ 23) ਲਕਸ਼ਦੀਪ ਦੇ ਆਵਾਜਾਈ ਦੇ ਸਾਧਨ ਦੇ ਵਿਸ਼ੇ ਤੇ ਇੱਕ ਪ੍ਰੋਜੈਕਟ ਬਣਾਓ।  
ਰੋਲ ਨੰਬਰ (24 ਤੋਂ 46) ਤੱਕ - ਅੰਡੇਮਾਨ ਨਿਕੋਬਾਰ ਦੇ ਵਿਸ਼ੇ ਤੇ ਫ਼ਸਲਾਂ ਤੇ ਇੱਕ ਪ੍ਰੋਜੈਕਟ ਬਣਾਓ।

## SUBJECT- MATHEMATICS

### GENERAL INSTRUCTIONS:-

1. Attempt Project work on coloured A4 size sheet.
2. All questions are compulsory to attempt.
3. Worksheets should be done neatly on A4 size ruled sheets and should be submitted in file/folder.

### PROJECT WORK:-

Compare the tourism of last ten years of following union territories with the help of Bar graph :-

Roll no. (1 to 25) - For Lakshadweep

Roll no. (26 onwards) - For Andaman and Nicobar

## WORKSHEET 1

### CHAPTER 1

Q- 1 Write the additive inverse of the following :-

- i)  $-6/-5$       ii)  $2/-7$       iii)  $-5/11$

Q-2 Find the multiplicative inverse of the following:

- i)  $-17$       ii)  $-12/17$       iii)  $15/16$

Q-3 Give one example showing associative property of rational numbers.

Q-4 Write three rational numbers greater than  $-3$ .

5. Calculate:-

$$(a) \frac{-4}{5} \times \frac{3}{7} + \frac{4}{5} \times \frac{3}{7}$$

$$(b) \frac{1}{2} \times \frac{5}{6} + \frac{1}{3} \times \frac{1}{4}$$

Q-6 \_\_\_\_\_ is the multiplicative inverse of  $5/2$ .

Q-7 By what number should we multiply  $-8/13$  to get the product 32?

Q-8 Show that:-

$$\left(\frac{-8}{9} \times \frac{1}{-5}\right) + \left(\frac{-8}{9} \times \frac{-7}{11}\right) = \frac{-8}{9} \times \left(\frac{1}{-5} + \frac{-7}{11}\right)$$

Q-9. If  $x = \frac{1}{7}$ ,  $y = \frac{2}{3}$  and  $z = -\frac{1}{3}$ . Verify that

$$x(y+z) = (xy) + (xz)$$

Q-10 If the cost of  $\frac{9}{2}$  litres of milk is ₹  $\frac{357}{4}$ , find the cost of 1 litre of milk.

## WORKSHEET 2

### CHAPTER 2

Q-1 Solve:-  $3(2x - 3) = 4(2x + 4)$

Q-2 Find the value of x:-

$$4x+5=7-8x$$

Q-3 Solve and verify your answer:-

$$11 - 5x + 3x + 4x = 18$$

Q-4 Solve:-  $(2x-2)+(3x-3)+(9x-9) = 1$

Q-5 Solve for x :-  $5x+21 = 2x(x+21)$

Q-6 Find the value of x:-

$$3x/2 - 2x/3 = 8$$

Q-7 Find the value of a, if

$$(a+3)(a-3)-a(a+5) = 6$$

Q-8 If 7 is added to 7 times a number, the result is 28. What is the number?

Q-9 A triangle having a perimeter 56 and its side are  $2x$ ,  $2x+3$  and  $2x+5$ . Find the respective lengths of the sides of the triangle.

Q-10 In a class of 96 students, the number of girls are three-fifths of the number of boys. Find the number of boys and girls in the class.

## WORKSHEET 3

### CHAPTER 3

Q-1 A quadrilateral has three acute angles, each measure  $80^\circ$ . What is the measure of the fourth angle?

Q-2 In a quadrilateral ABCD,  $\angle D$  is equal to  $150^\circ$  and  $\angle A = \angle B = \angle C$ . Find  $\angle A$ ,  $\angle B$  and  $\angle C$ .

Q-3 Name two quadrilaterals in which diagonals bisect each other.

Q-4 Name two quadrilaterals in which diagonals are equal to each other.

Q-5 Name two quadrilaterals in which diagonals are perpendicular to each other.

Q-6 The opposite angles of a parallelogram are  $(3x + 5)^\circ$  and  $(61 - x)^\circ$ . Find the measure of four angles.

Q-7 Find the value of  $x, y, z$ .

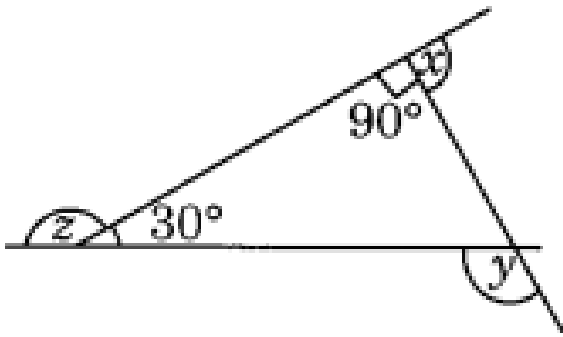

Q-8 Find the unknown values of  $x, y, z$ .

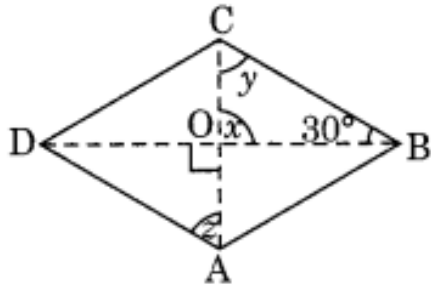

Q-9 Find the value of  $x, y$  if  $ABCD$  is a parallelogram.

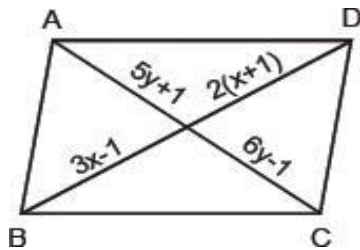

Q-10 Find the value of  $x$  and  $y$  if  $PQRS$  is a parallelogram.

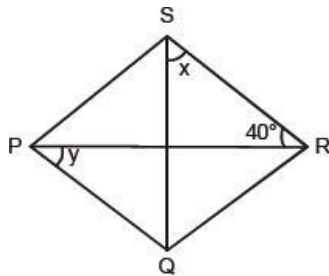

## **SCIENCE**

**1. Prepare a working model on any of the below mentioned**

**Topics:**

**a) Science and Technology in field of agriculture.**

**b) Agriculture and Human Welfare.**

**Use these links for reference: <https://youtu.be/BXpvBkUYNZM>**

**<https://youtu.be/Nlo8ggkkaam>**

**<https://youtu.be/7CYkfwke9tU>**

**Roll No 1 to 25 – Will work on the crops of Lakshwadeep island**

**Roll No 25 onwards – Will work on the crops of Andaman and Nicobar islands**

**2. Prepare pamphlets to promote “Organic Farming” in order to Spread awareness on Good Agricultural Practices.**

**3. Complete all the activities in your science practical file. (PDF SHARED IN CLASS GROUP)**

**4. Complete the given worksheet of chapter 1**

# CLASS 8

## Subject: Science

### Chapter 1- Crop Production and Management

#### Worksheet

**Multiple choice questions:**

- 1) The crops that are sown in the rainy season are called \_\_\_\_\_  
(a) Kharif crops                      (b) rabi crops                      (c) cash crops                      (d) none of these
- 2) Which of the following is not a rabi crop?  
(a) wheat                      (b) potato                      (c) rice                      (d) mustard
- 3) The process of loosening and turning of the soil is called \_\_\_\_\_  
(a) ploughing                      (b) levelling                      (c) manuring                      (d) none of these
- 4) Animals kept on farm are called \_\_\_\_\_  
(a) livestock                      (b) pets                      (c) farm animals                      (d) none of these
- 5) Cultivating crops and rearing animals in individual farms is called \_\_\_\_\_  
(a) farming                      (b) agriculture                      (c) mixed farming                      (d) none of these
- 6) A farmer perform some tasks for cultivation of a crop are called \_\_\_\_\_  
(a) sowing                      (b) preparation of soil                      (c) agricultural practices                      (d) none of these

**Answer the following questions in short:**

1. What do you understand by agriculture?  
\_\_\_\_\_  
\_\_\_\_\_
2. What is the traditional method of sowing the seeds?  
\_\_\_\_\_  
\_\_\_\_\_
3. What is the special requirement of planting paddy saplings for transplantation?  
\_\_\_\_\_  
\_\_\_\_\_
4. What is multiple cropping?  
\_\_\_\_\_  
\_\_\_\_\_
5. Define harvesting?  
\_\_\_\_\_  
\_\_\_\_\_



**Complete the following word puzzle with the help of clues given below.**

**Down**

1. Providing water to the crops.
2. Keeping crop grains for a long time under proper conditions.
5. Certain plants of the same kind grown on a large scale.

**Across**

3. A machine used for cutting the matured crop.
4. A rabi crop that is also one of the pulses.
6. A process of separating the grain from chaff.

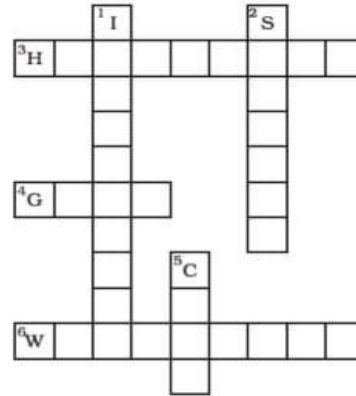

**Identify the following agricultural practices:**



(a) \_\_\_\_\_



(b) \_\_\_\_\_



(c) \_\_\_\_\_

**Write one word for the following:**

1. Undesirable plants which are grown along with crop \_\_\_\_\_ .
2. To turn the soil and loosen it. \_\_\_\_\_
3. Bacteria present in the root of leguminous plants. \_\_\_\_\_
4. Rearing of animals at large scale. \_\_\_\_\_

**Write any four sources of irrigation .**

\_\_\_\_\_

**What does the following picture represent?**



\_\_\_\_\_

## **SUBJECT : SOCIAL SCIENCE.**

1. **Integrated Project:** Pairing of Delhi with Andaman & Nicobar Island and Lakshadweep Island.
  - a) Write about Latitudinal and Longitudinal location of Delhi with Andaman & Nicobar Island and Lakshadweep Island and write few lines on 3 States with map and pictures.
  - b) Write about famous historical places of each with pictures.
2. Make a project file related to any famous freedom fighter of your choice in five pages with pictures.
3. Make a poster on A4 size with slogan on “Conservation of Flora & Fauna of India”.
4. Design a preamble for your school abiding to all rights and duties of all the students in school. You can also take help from preamble of constitution of India.
5. Collect information on G-20 summit 2023-24 from the newspapers and make a beautiful collage on full chart paper with all details and proper headings.

### **G.K**

**Read the newspaper daily and write four current affairs in a small notebook daily.**

### **DIVINITY**

**Make an activity for four Sahibzadas of Guru Gobind Singh Ji.**

### **ART**

- **Prepare a poster on BEACH SCENE.**
- **Project- Sea shell jewellery**
  - Bottle/Pot decoration with shells**
  - Wind chime with shells**

### **COMPUTER**

**Make a documentary video of Andaman and Nicobar island by using Krita and open short video editor**